



Indoor Models

**Indoor and Outdoor
Models**
**Pump Mounted Models
Available**
5 Year Limited Warranty



Available in Indoor and Outdoor Models

▶ 136,000 thru 1,826,000 BTU/Hr.

Rheem-Ruud hot water supply heaters are designed to provide hot water service to a variety of commercial applications when used in conjunction with an appropriately sized storage tank. These models are particularly suited for applications that require high inputs and large volumes of stored hot water.

Construction Features:

- **Reliable heat exchanger Design** – The all copper heat exchanger is a single bank, straight-through design with a floating return header immune to thermal shock.
- **Energy saving pump control** – The energy saving pump control is an electric device that allows the operator to set the desired time for the pump to run after the water heater shuts off. With the energy saving pump control the water heater pump is programmed to continue running for an optimum period of time in order to absorb the residual heat from the combustion chamber and use it in the system.
- **Compact design** – The low water heater mass design offers substantial savings in weight and cube over most cast iron, steel tube and storage-type water heaters making it ideal for rooftop installations and in tight quarters.
- **Minimal heat loss design** – Spark-to-pilot (IID) system is standard on all models.
- **Glasslined cast iron headers** – To handle aggressive water conditions. (Models GBBP/GBB136 feature bronze headers.)

Certifications and Ratings:

- **Efficiency** – These models have been tested according to ANSI test procedures, and meet or exceed the 80% thermal efficiency requirement of ASHRAE Standard 90.1b-1992 (Part of the Federally mandated Energy Policy Act (EPAct)). Also exceeds energy efficiency codes of all states.
- **Safety and Construction** – These products are design certified by the CSA: a) As a Hot Water Supply Water Heater equipped with on/off controls for use in conjunction with a storage tank. b) For operation at 180°F. c) To meet all safety and construction requirements of ANSI Z21.10.3.c) For installation on combustible flooring when used with a combustible floor base, and, or e) for alcove installation. ASME construction is standard on all models. **Certified for a 160 PSI Maximum Working Pressure.**

Three Important Reasons to Choose Hot Water Supply Heaters from Rheem-Ruud Commercial Water Heaters

Reliability

- Like all of our water heating products, Rheem-Ruud hot water supply heaters are crafted to exacting standards. Each detail of design, engineering and construction must meet our criteria for performance and durability.
- The **heat exchanger (1)**, for example, is constructed of 100% copper. **High Velocity hydraulics (2)** virtually eliminates problems of scaling and corrosion within its waterways. The **cast iron headers (3)** are glass-lined to assure that the entire heat exchanger assembly is resistant to corrosion.
- Every Rheem-Ruud hot water supply heater features **titanium stainless steel burners (4)**. They operate quietly, will not clog or corrode, and have far greater temperature resistance than cast iron. The **controls (5)** are factory adjusted and completely enclosed for reliable, automatic operation.
- The **outer jacket (6)** is galvanized and enamel baked for lasting aesthetics.

Efficiency

- Today's demands for volume hot water must be met economically, so we've attempted to use every fuel saving technique conceivable. The resulting 82% efficiency will save you money in fuel costs for years to come.
- The **integral finned copper tubing (7)** in the heat exchanger provides nine times more heat transfer area than smooth tubing. Efficiency is boosted even further by **V-baffles (8)**, which redirect the heat across the finned tubing. The **insulated combustion chamber (9)** features corner sealed and interlocking refractory panels to minimize chamber radiation losses.
- Economy is further enhanced with a special energy saving pump control. This automatic control continues to pump operation until all usable heat has been absorbed from the combustion chamber and stored in the tank.
- Access to water heater for inspection is simple. All Rheem-Ruud hot water supply heaters feature a **heat exchanger inspection panel (10)** and a removable door to access the **slide out burner drawer (11)**.

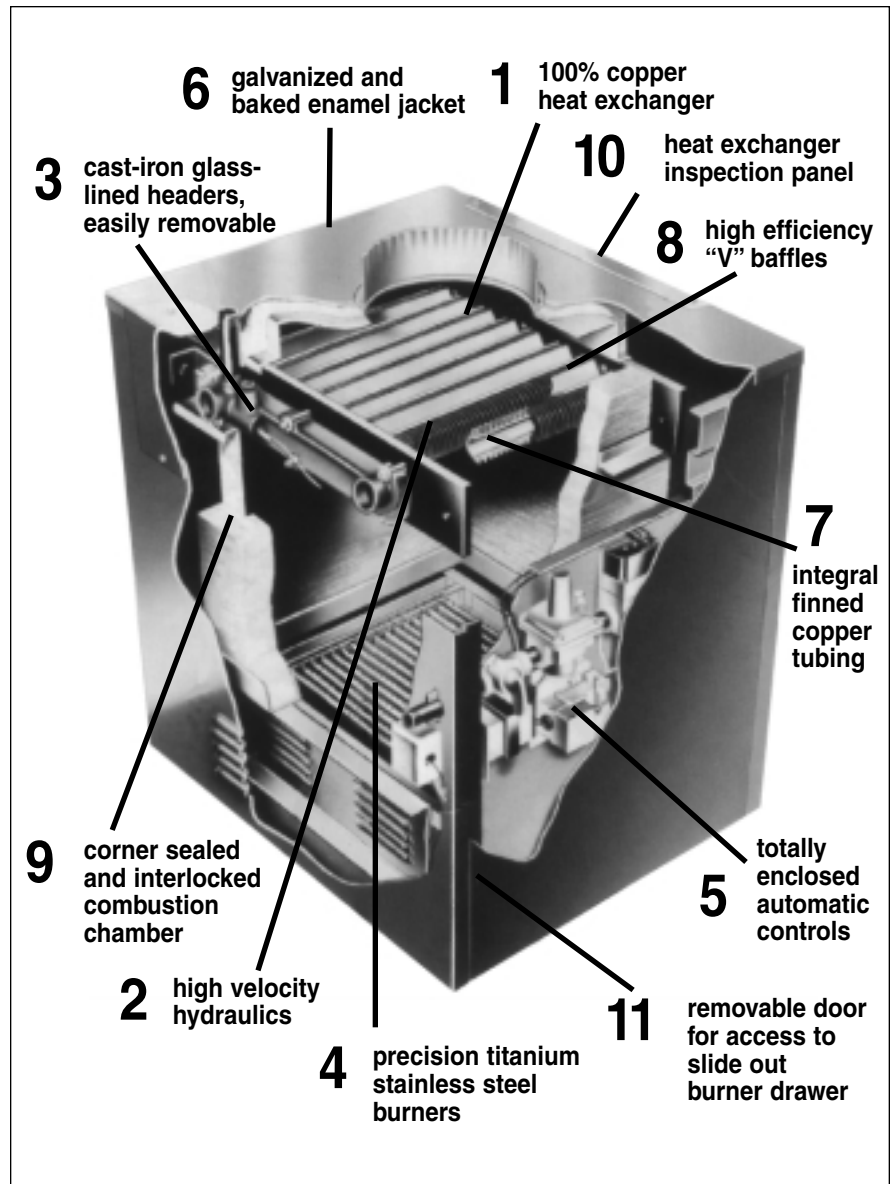

Flexibility

- You'll find that Rheem-Ruud hot water supply heaters are perfectly suited for many commercial, industrial and special application needs requiring economical, reliable supplies of hot water. The optional factory supplied pump is designed to handle nearly all water conditions
- Our standard sized water heaters – nine models ranging from 136,000 to 825,000 BTU – are designed for hot water supply in commercial applications. Each model is available for indoor and outdoor installation. The outdoor models feature a special draft system which is wind, rain and debris-proof.
- Our large sized water heaters – seven indoor and seven outdoor models ranging from 926,000 to 1,825,600 BTU – meet the heavier demand of larger multi-family housing and commercial applications. They are ideal for use as summer replacement water heaters, eliminating the need to fire large central heating water heaters merely to supply domestic hot water.
- All of these Rheem-Ruud hot water supply heaters are compact and convenient; they save space, fuel and installation cost.

Example System

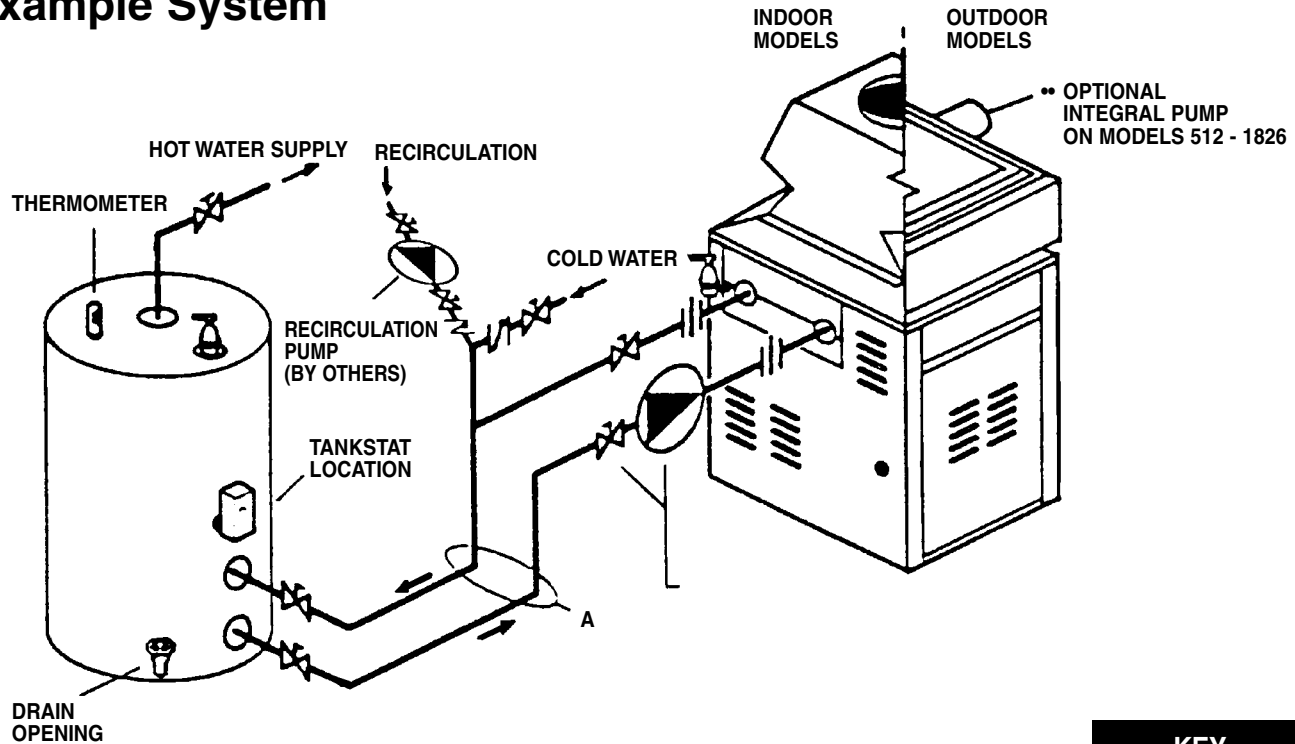

PUMP AND BALL VALVE LOCATION ON MODELS 136 THRU 399
 ** OPTIONAL ON MODELS 512 THRU 1826 WITHOUT INTEGRAL PUMP

- NOTES:
 1. PLUMB SWING CHECK VALVE IN GRAVITY CLOSED POSITION.
 2. MINIMUM PIPE EQUAL TO WATER HEATER INLET/OUTLET CONNECTION SIZE BETWEEN WATER HEATER AND TANK(S)
 3. PIPE ALL RELIEF VALVES TO DRAIN, OR AS LOCAL CODES REQUIRE

MINIMUM PIPE SIZE	
Model Size	Dimension A
136	1-1/4"
186-399	1-1/2"
512-825	2"
926-1826	2-1/2"

WATER HEATER SHOWN REPRESENTS VARIOUS MODELS. BECAUSE MODELS WILL VARY IN DRAFT HOOD DESIGN AND SIZE. SEE SPECIFIC WATER HEATER INFORMATION FOR DETAILS.

KEY	
	PRESSURE RELIEF VALVE
	UNION
	BALL VALVE
	GATE VALVE
	CHECK VALVE
	PUMP

Guaranteed 80% draw without temperature drop, using Rheem-Ruud water heaters, tanks, sizing tables and hook-up data.

JACKET INSULATED STORAGE TANKS BY RHEEM-RUUD (All dimensions shown in inches)								
Model	Capacity Gallons	Overall Height	Diameter	Connection Hot Outlet	Connections Circulating Line	Relief Valve Connection	Approx. Shipping Weight (Lbs.)	
							Standard	ASME
ST80(A)	80	58-5/16	24-7/16	2	2	1	220	260
ST120(A)	115	59-1/4	28-1/4	2	2	1	260	340
ST175(A)	175	67-1/4	32-1/4	2-1/2	2-1/2	1	600	600
ST200A	200	77-1/4	32	2	2-1/2	1	N/A	500
ST260A	257	95-1/2	34	2	3	1-1/4	N/A	1108
ST320A	318	84-1/2	40	2	3	1-1/4	N/A	1290
ST430A	432	84-1/2	46	2	3	1-1/4	N/A	1626
ST500A	504	94-1/2	46	2	3	1-1/4	N/A	1765
ST750A	752	107-1/2	54	2	3	1-1/4	N/A	2330
ST950A	940	131-1/2	54	2	3	1-1/4	N/A	3010

These storage tanks meet standby loss requirements of ASHRAE 90.1b-1992.
 (A) ASME code constructed tanks available as an option.
 Consult specification sheet for complete details.

SPECIFICATIONS AND DIMENSIONS

Ref. to Dwg.	MODEL NUMBER		STYLE		MBTUH NATURAL GAS (X 1000)				DIMENSIONS (INCHES)							SHIPPING WEIGHT††			
	With-out Pump	With Pump	In-door	Out-door	(indoor)		(outdoor)		Width A	Height Overall B	Jacket Height C	Gas Conn. G	J	Flue Dia. K	L	M	N	(Indoor)	(Outdoor)
					Input	Output	Input	Output											
1	GBB136*	GBBP136*	•	•	136.0	112.0	136.0	112.0	24"	45.0	30%	1/2"	-	6	9 1/4"	10 1/4"	3 1/2"	195	195
2	GBC186**	GBCP186**	•	•	181.0	148.0	181.0	148.0	18 1/2"	40.0	38	1/2"	12 1/2"	6	-	-	-	191	200
	GBC264**	GBCP264**	•	•	264.0	216.0	264.0	216.0	22"	40.0	38	1/2"	11 1/2"	7	-	-	-	214	220
	GBC331**	GBCP331**	•	•	334.0	274.0	334.0	274.0	25"	40.0	38	1/2"	10 1/2"	8	-	-	-	234	240
	GBC399**	GBCP399**	•	•	399.0	327.0	399.0	327.0	29"	40.0	38	1/2"	12 1/2"	9	-	-	-	253	260
3	GBC512	GBCP512	•	•	511.5	419.4	511.5	419.4	32"	57.0	33	1"	-	10	25 1/2"	-	-	510	535
	GBC627	GBCP627	•	•	627.0	514.1	627.0	514.1	37 1/2"	57.0	33	1"	-	12	29 1/2"	-	-	520	545
	GBC726	GBCP726	•	•	726.0	595.4	726.0	595.4	41"	57.0	33	1"	-	12	34 1/2"	-	-	630	685
	GBC825	GBCP825	•	•	825.0	676.5	825.0	676.5	45"	57.0	33	1"	-	14	38 1/2"	-	-	660	720
4	GBC926	GBCP926	-	•	-	-	926.0	759.3	52%	-	-	1"	-	-	-	-	-	-	790
	GBC962	GBCP962	•	-	961.7	788.6	-	-	52%	68%	33 1/2"	1"	18	14	28	-	-	760	-
	GBC1083	GBCP1083	-	•	-	-	1083.0	888.1	59%	-	-	1"	-	-	-	-	-	-	850
	GBC1125	GBCP1125	•	-	1124.7	922.2	-	-	59%	74%	33 1/2"	1"	25 1/2"	16	32	-	-	800	-
	GBC1178	GBCP1178	-	•	-	-	1178.0	966.0	63%	-	-	1"	-	-	-	-	-	-	910
	GBC1223	GBCP1223	•	-	1222.5	1002.4	-	-	63%	74%	33 1/2"	1"	23%	16	32	-	-	860	-
	GBC1287	GBCP1287	-	•	-	-	1287.0	1055.3	68%	-	-	1 1/4"	-	-	-	-	-	-	975
	GBC1337	GBCP1337	•	-	1336.6	1096.0	-	-	68%	76 1/2"	33 1/2"	1 1/4"	23%	18	36	-	-	930	-
	GBC1413	GBCP1413	-	•	-	-	1413.0	1158.7	74%	-	-	1 1/4"	-	-	-	-	-	-	1065
	GBC1467	GBCP1467	•	-	1467.0	1202.9	-	-	74%	76 1/2"	33 1/2"	1 1/4"	23%	18	36	-	-	1000	-
	GBC1570	GBCP1570	-	•	-	-	1570.0	1287.4	81%	-	-	1 1/4"	-	-	-	-	-	-	1120
	GBC1630	GBCP1630	•	-	1630.0	1336.5	-	-	81%	79%	36 1/2"	1 1/4"	23%	18	36	-	-	1040	-
	GBC1758	GBCP1758	-	•	-	-	1758.0	1441.6	89%	-	-	1 1/4"	-	-	-	-	-	-	1150
	GBC1826	GBCP1826	•	-	1825.6	1496.9	-	-	89%	81%	36 1/2"	1 1/4"	23%	20	40	-	-	1090	-

* Equipped with bronze headers, all other models have glassined cast iron headers. GBC - cast iron headers. GBB - bronze headers.

†† Subtract 55 lbs. when ordering GBC models.

** Low NOx models add "N" after model number. Outdoor models add "-O" after model number. Indicate Natural or LP when ordering.

MBTUH PROPANE GAS†	
Model Size	Multiplier
136-399	Same as natural gas
512-825	.94
926-1826	.92 Indoor
	.955 Outdoor (input)
	.92 Outdoor (output)

MIN. CLEARANCES TO COMBUSTIBLE SURF.					
Model Size	Rear	Left Side	Right Side	Top	
				Indoor	Outdoor
136	12"	12"	6"	42"	Unobstr.
186-399	12"	12"	12"	39"	Unobstr.
512-825	12"	18"	6"	36"	Unobstr.
926-1826	24"	24"	24"	24"	Unobstr.

For servicing provide 24" minimum unobstructed clearance in front of unit.

ELECTRICAL RATINGS	
Model Size	With Pump
136-399	3.7 amps @ 120V (1/8 hp pump)
331-399	3.6 amps @ 120V (1/6 hp pump)
512-1826	7.2 amps @ 120V (1/2 hp pump)

† Multiplier x Nat. MBTUH = Pro. MBTUH

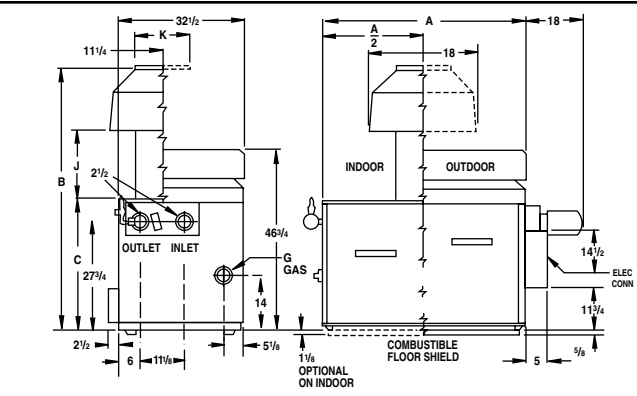
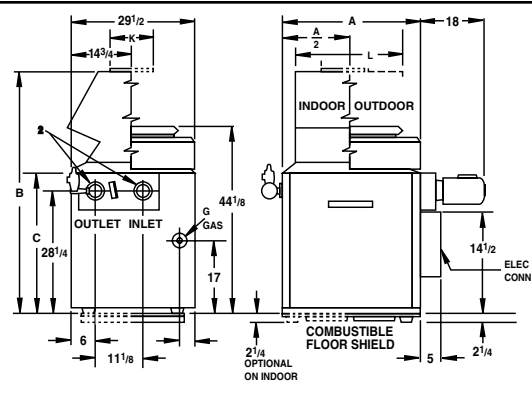
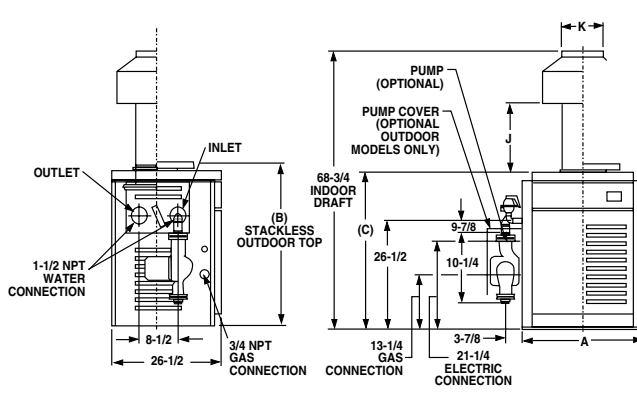
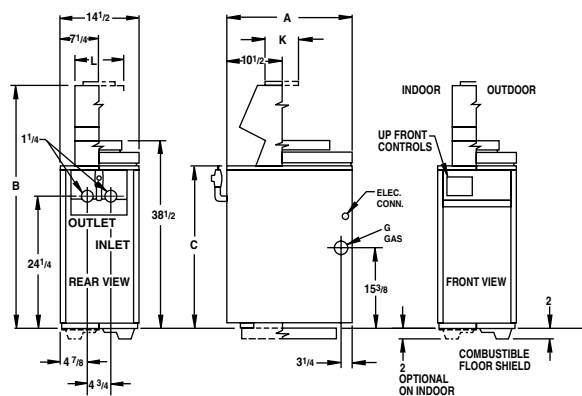

RECOVERY CAPACITIES

MODEL NUMBER		STYLE		INPUT BTU/Hr. NATURAL	TEMPERATURE RISE – DEGREES F – GALLONS PER HOUR										
w/Pump	w/Pump	Indoor	Outdoor		40°	50°	60°	70°	80°	90°	100°	110°	120°	130°	140°
GBB136	GBBP136	*	*	136,000	330	264	220	188	165	147	132	120	110	101	94
GBC186	GBCP186	*	*	181,000	440	352	293	251	220	195	176	160	147	135	126
GBC264	GBCP264	*	*	264,000	640	512	427	366	320	284	256	233	213	197	183
GBC331	GBCP331	*	*	334,000	811	649	541	463	406	360	324	295	270	250	232
GBC399	GBCP399	*	*	399,000	967	774	645	553	484	430	387	352	322	298	276
GBC512	GBCP512	*	*	511,500	1240	992	827	709	620	551	496	451	413	382	354
GBC627	GBCP627	*	*	627,000	1520	1216	1013	869	760	676	608	553	507	468	434
GBC726	GBCP726	*	*	726,000	1760	1408	1173	1006	880	782	704	640	587	542	503
GBC825	GBCP825	*	*	825,000	2000	1600	1333	1143	1000	889	800	727	667	615	571
GBC926	GBCP926		*	926,000	2245	1796	1497	1283	1122	998	898	816	748	691	641
GBC962	GBCP962	*		961,700	2331	1865	1554	1332	1166	1036	933	848	777	717	665
GBC1083	GBCP1083		*	1,083,000	2625	2100	1750	1500	1313	1167	1050	955	875	808	750
GBC1125	GBCP1125	*		1,124,700	2727	2181	1818	1558	1363	1212	1091	991	909	839	779
GBC1178	GBCP1178		*	1,178,000	2856	2285	1904	1632	1428	1269	1142	1038	952	879	816
GBC1223	GBCP1223	*		1,222,500	2964	2371	1976	1694	1482	1317	1185	1078	988	912	847
GBC1287	GBCP1287		*	1,287,000	3120	2496	2080	1783	1560	1387	1248	1135	1040	960	891
GBC1337	GBCP1337	*		1,336,600	3240	2592	2160	1852	1620	1440	1296	1178	1080	997	926
GBC1413	GBCP1413		*	1,413,000	3425	2740	2284	1957	1713	1522	1370	1246	1142	1054	979
GBC1467	GBCP1467	*		1,467,000	3556	2845	2371	2032	1778	1581	1423	1293	1185	1094	1016
GBC1570	GBCP1570		*	1,570,000	3806	3045	2537	2175	1903	1692	1522	1384	1269	1171	1087
GBC1630	GBCP1630	*		1,630,000	3952	3161	2634	2258	1976	1756	1581	1437	1317	1216	1129
GBC1758	GBCP1758		*	1,758,000	4262	3409	2841	2435	2131	1894	1705	1550	1421	1311	1218
GBC1826	GBCP1826	*		1,825,600	4426	3541	2950	2529	2213	1967	1770	1609	1475	1362	1264

GENERAL FLOW AND PIPING SPECIFICATIONS

MODELS		Water Hardness														
		SOFT					MEDIUM					HARD				
		0-4 Grains Per Gallon					5-15 Grains Per Gallon					16 & Over Grains Per Gallon				
Indoor	Outdoor	ΔT	GPM	ΔP	MPS	SHL	ΔT	GPM	ΔP	MPS	SHL	ΔT	GPM	ΔP	MPS	SHL
136	136	22	10	3.4	1-1/4	5.09	17	13	5.5	1-1/4	8.2	10	22	14.7	1-1/4	22
186	186	15	20	1.82	1-1/2	4.48	11	26	3	1-1/2	7.5	7	40	6.8	1-1/2	17
264	264	21	20	1.85	1-1/2	4.51	16	26	3.1	1-1/2	7.6	10	42	8.3	1-1/2	18.8
331	331	27	20	1.9	1-1/2	4.56	20	26	3.2	1-1/2	7.7	13	42	8.5	1-1/2	19
399	399	30	22	2.1	1-1/2	5.08	25	26	3.3	1-1/2	7.8	15	43	9	1-1/2	19.5
512	512	20	42	1.8	2	4.4	16	52	2.9	2	7	10	84	6.8	2	16.6
627	627	25	41	1.9	2	4.5	19	54	3.1	2	7.2	11	90	8.5	2	20.4
726	726	29	41	2	2	4.6	20	60	4	2	9.3	13	90	9	2	20.8
825	825	30	45	2.5	2	5.7	20	68	5.2	2	11.7	15	90	9.3	2	21.1
962	926	30	53	3.5	2-1/2	4.9	20	79	7.5	2-1/2	10.5	17	90	10.1	2-1/2	14.3
1125	1083	30	61	5.5	2-1/2	7.5	20	90	11.8	2-1/2	16	20	90	11.8	2-1/2	16
1223	1178	30	67	6.5	2-1/2	8.8	22	90	12	2-1/2	16.2	22	90	12	2-1/2	16.2
1337	1287	30	73	8.4	2-1/2	11	24	90	13.3	2-1/2	17.5	24	90	13.3	2-1/2	17.5
1467	1413	30	80	10.8	2-1/2	14.1	26	90	13.8	2-1/2	18	26	90	13.8	2-1/2	18
1630	1570	30	89	13.7	2-1/2	17.6	29	90	14.8	2-1/2	19	29	90	14.8	2-1/2	19
1826	1758	32	90	15.5	2-1/2	19.7	32	90	15.5	2-1/2	19.7	32	90	15.5	2-1/2	19.7

NOTE: Additional pipe fittings will increase the system head loss. Select a pump based on the water hardness, flow and system head loss. If water heater is more than two stories above the tank, consult the pump manufacturer.

ΔT	– Temperature Rise, Degree F @ GPM Flow
GPM	– Gallons per Minute Flow
ΔP	– Pressure Drop, Ft. thru Heat Exchanger
MPS	– Minimum Pipe Size, NPT
SHL	– System Head Loss

Sizing based on water heater and tank being placed 5 feet apart. The equivalent length of pipe valves and fittings in the system is as follows.
1-1/4" NPT = 65 Ft (136)
1-1/2" NPT = 70 Ft (186-399)
2" NPT = 75 Ft (512-825)
2-1/2" NPT = 80 Ft (926-1826)

Gas Hot Water Supply Heaters

Standard Equipment:

Heat Exchanger

- Finned Copper Tubes
- ASME Steel Tubesheet
- Silicon O-Rings
- 125 PSIG ASME Pressure Relief Valve
- Glasslined Cast Iron Headers

Controls

- Energy Saving Pump Control
- Flow Switch
- Spark-to-Pilot Ignition System
- High Limit Control
- On/Off Switch
- Flue Gas Spillage Sensor
- Flame Roll-Out Sensor

Gas Control Train

- Manual Gas Shut-Off Cock
- Main Gas Pressure Regulator
- Safety Shut-Off Valve, Redundant
- Control Valve

Construction

- Vent Terminal
- Front Controls Enclosed
- Stainless Steel Burners
- Polytuf Powder Coat Finish

When ordering specify:

- | | | |
|--|----|--|
| <input type="checkbox"/> wo/Pump (GBC) | or | <input type="checkbox"/> w/Pump (GBCP) |
| <input type="checkbox"/> Natural Gas | or | <input type="checkbox"/> L.P. |
| <input type="checkbox"/> Indoor | or | <input type="checkbox"/> Outdoor |

Recommended Specifications:

Hot Water Supply Heater(s) shall be model _____, manufactured by RHEEM-RUUD, having gas input of _____ Btu/hr. and recovery rate of _____ GPH at a 100°F temperature rise when tested and certified at _____ thermal efficiency. Water heaters(s) shall have the CSA seal of certification and supplied with a factory installed 125 PSIG ASME pressure relief valve. Water heater(s) shall meet or exceed the thermal efficiency requirements of ASHRAE Standard 90.1b-2000. Water heater(s) shall be ASME inspected and stamped for 160 PSI working pressure complete with manufacturer's data report. Water tube heat exchanger shall be constructed of straight integral copper fin tubes with fins spaced at seven fins per inch. Tube sheets shall be ASME fire box steel. Headers shall be of glasslined cast iron and joined to the copper tubes and tube sheets by means of silicone "O" rings to form a positive seal between the copper tubes and the headers to 1200 PSI hydrostatic pressure. Headers shall be secured to the tube sheets by properly spaced bolts and flange nuts. Heat exchanger shall be readily cleanable from either the right or left sides (or rear) of the water heater by removing header(s), and on the right side, cleanable without removing external piping. Heat exchanger to be explosion proof on the water side. Waterways to be 100% copper and glasslined cast iron to prevent galvanic action within the water heater by positively sealing off water contact between ferrous and non-ferrous metals. Pump, flow switch, and energy saving pump control are to be factory supplied and units over 400,000 Btu/Hr. must have electronic intermittent pilot ignition.

Water heater to be equipped with remote bulb electric high limit control adjustable to 200°F. Main electric gas valve to be 24 volt with 110/24 volt transformer. Gas pressure regulator to be factory set at 4" W.C. Flame supervision shall be either 60 second thermopilot or 1-4 second electronic shut down.

Burners to be raised port and die formed from stainless steel alloy, mounted on a removable drawer, capable of quiet ignition and extinction, and equipped with fixed primary air ports.

Models above 330,000 Btu/Hr. shall be CSA design certified for a minimum efficiency of 82% on indoor and outdoor models.

Limited Warranty

All GB models feature a five year limited warranty on the copper heat exchanger and glasslined cast iron header. Please refer to Commercial Warranty Information brochure for complete limited warranty information.



**COMMERCIAL
WATER HEATERS**

In keeping with its policy of continuous progress and product improvement, Rheem-Ruud reserves the right to make changes without notice.

Rheem Water Heaters • 101 Bell Road, Montgomery, Alabama 36117-4305 • www.rheem.com