



208, 240,
277 and 480
Voltages

Immersion
Thermostat(s)



10 Gallon Capacity

► 6KW thru 54KW

Rheem-Ruud Electric Booster Water Heaters are specifically designed to fit under counters and deliver 180°F sanitizing rinse water for all stationary rack and conveyor type commercial dishwashers. They will raise preheated or cold water to 180°F rinse temperature for compliance with UL Sanitation (NSF5) and all Federal, State, County and Local Health Department Sanitation Codes. In addition, these models can be used as circulating tank commercial electric water heaters for gravity or pump circulation to an auxiliary storage tank.

Construction Features:

- **System Sentinel –** all electric booster models employ an element diagnostic panel, utilizing light emitting diodes (L.E.D.), corresponding to the number and location of each heating element. L.E.D.'s are energized when the electric elements are operating. An unlit L.E.D. pinpoints the exact location of a non-functioning element, making element operation diagnosis simple and positive.
- **Long life tank design –** proprietary steel formulation with a unique coat of high temperature porcelain enamel to maximize corrosion resistance resulting in a superior tank design.
- **Long life heating elements –** separate screw-in type elements feature a Nichrome wire filament, embedded in magnesium oxide sealed in a copper tube to resist water chemical corrosion...for long element life and a long life performance. Elements are directly immersed in the water for maximum recovery efficiency (98%) and are easily changed by simply screwing new ones into the tank.

Certifications and Ratings:

- **Efficiency –** these models meet the energy efficiency levels of ASHRAE Standard 90.1b-2001 (Part of the Federally mandated Energy Policy Act (EPact)). Also exceeds energy efficiency codes of all states including California Energy Commission (CEC).
- **Safety and construction –** these products are design certified by Underwriters Laboratories (UL) to meet UL standard 1453 as electric booster and commercial storage tank water heaters. All models are UL Sanitation (NSF5) and North Carolina Code compliant.
CERTIFIED FOR A 150 PSI MAXIMUM WORKING PRESSURE.

ELECTRICAL CHARACTERISTICS											
INPUT KW	NUMBER OF ELEMENTS	ELEMENT WATTAGE	FULL LOAD CURRENT IN AMPERES							IMMERSION THERMOSTATS	
			208V		240V		277V	480V		Number of Contactors	Number of Fuses
			Phase		Phase		Phase	Phase			
			1	3	1	3	1	1	3		
6	3	2000	29	17	25	14	22	13	7	2	6
9	3	3000	43	25	38	22	33	19	11	2	6
12	3	4000	58	33	50	29	43	25	15	2	6
15	3	5000	72	42	63	36	54	31	18	2	6
18	3	6000	-	-	75	43	65	38	22	2	6
18	6	3000	87	50	-	-	-	-	-	4	12
24	6	4000	116	67	100	58	87	50	29	4	12
27	6	4500	130	75	113	65	98	56	33	4	12
30	6	5000	144	84	125	73	108	63	36	4	12
36	6	6000	-	-	150	87	130	75	43	4	12
36	9	4000	173	100	-	-	-	-	-	6	18
45	9	5000	217	125	188	109	163	94	54	6	18
54	9	6000	260	150	225	130	195	113	65	6	18

RECOVERY CAPACITIES													
Recovery in U.S. Gallons/Hr. (GPH) and Liters/Hr. (LPH) at Various Temperature Rises													
INPUT KW	EQUIVALENT BTU/HR.	UNITS	40° F (22° C)	50° F (28° C)	60° F (33° C)	70° F (39° C)	80° F (45° C)	90° F (50° C)	100° F (56° C)	110° F (61° C)	120° F (67° C)	130° F (72° C)	140° F (78° C)
6	20,473	GPH	62	50	41	35	31	28	25	23	21	19	18
		LPH	235	188	157	134	117	104	94	85	78	72	67
9	30,710	GPH	93	74	62	53	47	41	37	34	31	29	27
		LPH	352	282	235	201	176	157	141	128	117	108	101
12	40,946	GPH	124	99	83	71	62	55	50	45	41	38	35
		LPH	470	376	313	268	235	209	188	171	157	145	134
15	51,183	GPH	155	124	103	89	78	69	62	56	52	48	44
		LPH	587	470	391	335	294	261	235	213	196	181	168
18	61,420	GPH	186	149	124	106	93	83	74	68	62	57	53
		LPH	705	564	470	403	352	313	282	256	235	217	201
24	81,893	GPH	248	199	165	142	124	110	99	90	83	76	71
		LPH	939	751	626	537	470	417	376	342	313	289	268
27	92,129	GPH	279	223	186	160	140	124	112	102	93	86	80
		LPH	1057	845	705	604	548	470	423	384	352	325	302
30	102,366	GPH	310	248	207	177	155	138	124	113	103	95	89
		LPH	1174	939	783	671	587	522	470	427	391	361	335
36	122,839	GPH	372	298	248	213	186	165	149	135	124	115	106
		LPH	1409	1127	939	805	705	626	564	512	470	434	403
45	153,549	GPH	465	342	310	266	233	207	186	169	155	143	133
		LPH	1761	1409	1174	1006	881	783	705	640	587	542	503
54	184,259	GPH	558	447	372	319	279	248	223	203	186	172	160
		LPH	2114	1691	1409	1208	1057	939	845	769	705	650	604

Factory Accessories From Rheem-Ruud:

Solid state low water cut-off – probe type cut-off for field installation (AP8408).

MODEL NUMBERS	INPUT KW	
E10-6-G	6	<p>Fuse type – the “G” in the model number represents Class G fuses.</p> <p>Fuseless construction – any standard model not exceeding 48 Amps (See “Electrical Characteristics” Table) may be ordered without element fuses. Add “N” after the fuse type designation. Example: E10-9-G becomes E10-9-GN</p> <p>Approximate Shipping Weight – 110 lbs./50 kgs.</p>
E10-9-G	9	
E10-12-G	12	
E10-15-G	15	
E10-18-G	18	
E10-24-G	24	
E10-27-G	27	
E10-30-G	30	
E10-36-G	36	
E10-45-G	45	
E10-54-G	54	

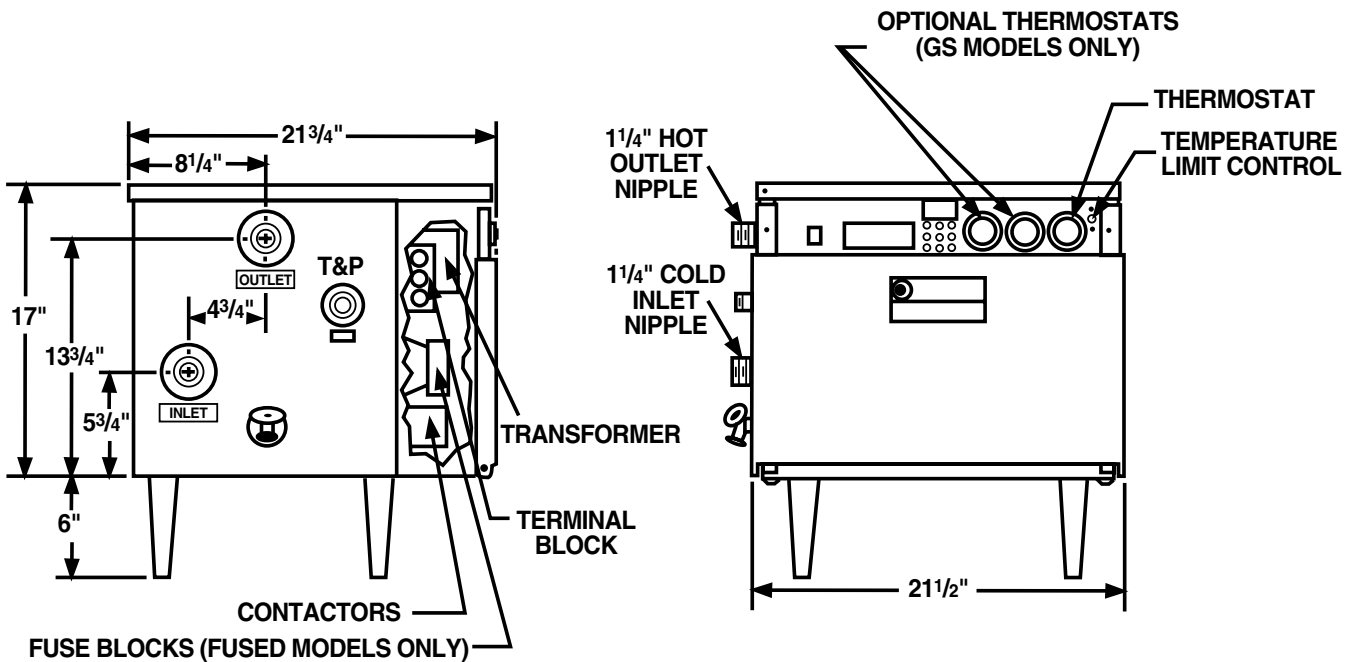

WATER TEMPERATURE RATINGS					
Model Number	Tank Capacity	Thermostat Type	Minimum Delivered Temperature	Maximum Delivered Temperature	High Temperature Limit
E10	10 Gal./ 38L	Immersion	90°F / 32.2°C	190°F / 87.8°C	200°F / 93.3°C

Other Features:

- **Integral fusing** – all models have integral fusing for each element.
- **Anode rods** – two (2) magnesium anodes are installed in each tank for maximum corrosion resistance.
- **Temperature and pressure relief valve** – AGA/ASME rated and factory installed.
- **Electrical connections** – pre-wired, accessible control box with multiple knock-outs on side in size selections to match the National Electric Code. Sizes range from 1/2" to 2". A grounding screw is provided for attaching an equipment grounding conductor.
- **Single panel control box** – with hinged stainless steel door, provides immediate access to all electrical components and elements.
- **Terminal block** – all models are equipped with UL Listed terminal blocks for simplicity of installation. The terminal block will accept either copper or aluminum field connect wire.
- **120 volt control circuit** – all units are furnished with a fused 120 volt control circuit. All controls (thermostats, high temperature limit, etc.) are operated off of this basic 120 volt control circuit. This circuit is created by an internal multi-tap transformer of unique design that has four (4) taps for the primary voltages, 208, 240, 277 and 480.
- **Water connections** – hot outlet and cold inlet are 1-1/4" NPT dielectric nipples which prevent excessive turbulence of heated water and results in optimum tank draw.
- **Heavy insulation** – an effective blanket of insulation completely surrounds tanks to limit heat loss and assure high operating efficiency.
- **Stainless steel legs** – 6" stainless steel legs are provided with each unit.

Recommended Specifications

Water heater(s) shall be model _____, manufactured by RHEEM-RUUD, having electrical input of _____ kW and a recovery rate of _____ GPH at a 100°F temperature rise. Water heater(s) shall have a storage capacity of 10 gallons. Water heater(s) shall have the UL seal of certification and be factory equipped with an AGA/ASME rated temperature and pressure relief valve. Tank(s) shall have a unique coating of high temperature porcelain enamel and furnished with magnesium anode rods rigidly supported. Water heater(s) shall meet or exceed the efficiency requirements of ASHRAE Standard 90.1b-2001. Tank(s) shall have a working pressure rating of 150 psi, and shall be completely assembled. Water heater(s) shall be approve-listed and constructed in accordance with UL Sanitation (NSF5). Water heater(s) shall be equipped with "screw-in" type elements. Water heater(s) shall be constructed with a SYSTEM SENTINEL element diagnostic panel utilizing light emitting diodes. Each LED will correspond to the number and location of the heating elements and monitor their on-off function. Water heater(s) shall be provided with internal power circuit fusing, control circuit fusing, magnetic contactors, 120 volt control circuit transformer and immersion thermostat(s) with manual reset high limit control. 1-1/4" inlet and outlet water connections shall be provided. Water heater(s) shall be covered by a three year limited warranty against tank leaks.

Limited Warranty

This product features a three year limited warranty against tank leaks. Please refer to Commercial Warranty Information brochure for complete warranty information.



**COMMERCIAL
WATER HEATERS**

In keeping with its policy of continuous progress and product improvement, Rheem-Ruud reserves the right to make changes without notice.

Rheem Water Heating • 101 Bell Road, Montgomery, Alabama 36117-4305 • www.rheem.com